

(19) World Intellectual Property Organization
International Bureau



(43) International Publication Date
1 February 2001 (01.02.2001)

PCT

(10) International Publication Number
WO 01/07892 A1

- (51) International Patent Classification⁷: **G01N 15/06**, [US/US]; 10080 Stichfield Woods Road, Pinckney, MI 31/00, 33/48, 33/92 48169 (US).
- (21) International Application Number: PCT/US00/20310 (74) Agents: **CONGER, William, G.** et al.; Brooks & Kushman, 22nd floor, 1000 Town Center, Southfield, MI 48075 (US).
- (22) International Filing Date: 25 July 2000 (25.07.2000)
- (25) Filing Language: English (81) Designated States (*national*): CA, JP, US.
- (26) Publication Language: English (84) Designated States (*regional*): European patent (AT, BE, CH, CY, DE, DK, ES, FI, FR, GB, GR, IE, IT, LU, MC, NL, PT, SE).
- (30) Priority Data: 60/145,880 27 July 1999 (27.07.1999) US
- (71) Applicant (*for all designated States except US*): **ESPERION THERAPEUTICS, INC.** [US/US]; 3621 S. State Street, 695 KMS Place, Ann Arbor, MI 48108 (US). **Published:**
— *With international search report.*
- (72) Inventor; and *For two-letter codes and other abbreviations, refer to the "Guidance Notes on Codes and Abbreviations" appearing at the beginning of each regular issue of the PCT Gazette.*
- (75) Inventor/Applicant (*for US only*): **REA, Thomas, J.**

(54) Title: METHOD AND DEVICE FOR MEASUREMENT OF CHOLESTEROL EFFLUX

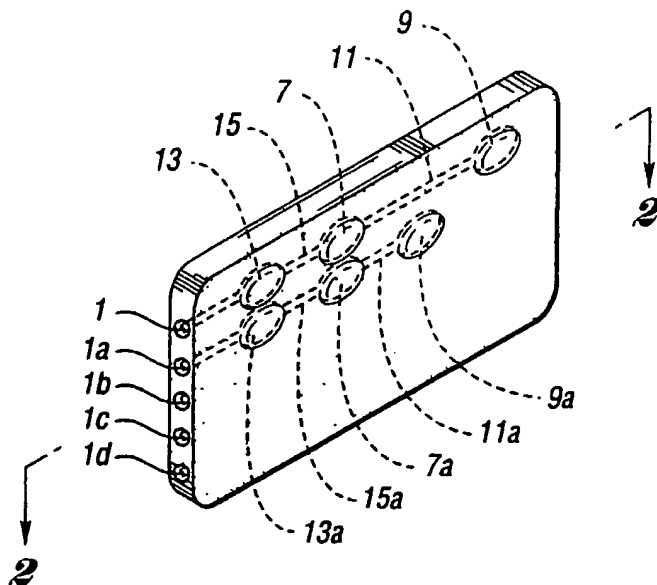

(57) Abstract: A device suitable for measurement of lipid efflux attributed to a blood plasma sample without in vitro cultivation of live cells employs a preferably microfluidics device having a bilayer lipid membrane or its equivalent in a membrane chamber (7), a measurement chamber (9), and a channel (15) connecting the two chambers. A device is preferably configured with a plurality of measurement pathways (1, 1a, 1b, 1c and 1d) with a corresponding plurality of membrane chambers and measurement chambers, and optionally one or more reservoir chambers (13). Use of the device obviates the problems of cell culture associated with present cholesterol efflux measurement.

WO 01/07892 A1

METHOD AND DEVICE FOR MEASUREMENT OF CHOLESTEROL EFFLUX

TECHNICAL FIELD

5 The present invention pertains to measurement of the biological fluid (e.g. plasma or serum)-induced exchange of lipids, particularly cholesterol, with lipid bilayers. The present invention further pertains to a device suitable for use in making such measurements.

BACKGROUND ART

10 Atherosclerosis is a vascular disease characterized by a luminal narrowing of an artery by a lesion or "atherosclerotic plaque". This causes a reduction in blood flow leading to an ischemia of the end organ. Studies in both human and experimental animal models have demonstrated a direct association between elevations in plasma cholesterol and accelerated atherosclerosis. It has been long known that the plaque is characterized by an accumulation of lipids, primarily 15 LDL cholesterol, in "fatty streaks". These fatty streaks contain monocyte-derived macrophages that have ingested massive amounts of lipid. Understandably, many researchers have focused on the how and why of cholesterol accumulation, as well as methods of reversing this accumulation.

20 HDL is a protein lipid complex that has been implicated in "reverse cholesterol transport", the process of removing cholesterol from the peripheral tissues to the liver. An increased level of HDL in the plasma has been correlated with a lower risk of atherosclerosis in humans. Much research continues to be devoted to the study of cholesterol, HDL, LDL, VLDL, and associated lipids, their actions, and interdependencies. For example, many candidate drugs have been tested 25 for their cholesterol and LDL lowering ability. Another desirable property sought after is the ability of candidate therapies to increase the removal of lipids from the wall of blood vessels, a process known as reverse lipid transport. One means for evaluating this property is to measure the capacity of plasma or serum to remove cholesterol from biological membranes. Currently, such activity is technically

demanding and time consuming due to its reliance on cell culture techniques. For example, researchers studying this process rely on cell culture-based assay systems to measure HDL-mediated cholesterol efflux from the cells. These assays are subject to the problems associated with all cell based systems. They are time consuming, subject to high variability, and require cell maintenance through a sterile culture system. Examples of such methods are those disclosed in "Cell cholesterol efflux: integration of old and new observations provides new insights"; JOURNAL OF LIPID RESEARCH 40:781-796, 1999; George H. Rothblat, Margarita de la Llera-Moya, Veronique Atger, Ginny Kellner-Weibel, David L. Williams, and Michael C. Phillips; and Shinji Yokoyama, BIOCHIMICA ET BIOPHYSICA ACTA, 1392 (1998) pp. 1-15, and the references cited therein. There is a need for a non-cell based assay to study both the influx and efflux of cholesterol and other lipids from cell membranes.

DISCLOSURE OF INVENTION

The present invention pertains to a rapid method of measuring flux of cholesterol and other lipid-associated compounds with membranes, these changes induced by blood plasma, which method does not require contact of blood plasma with living cells, and to devices suitable for use in such method. The method comprises contacting blood plasma with a supported, lipid-containing membrane and then measuring the resulting flux of cholesterol or other lipid or lipid-associated compound into or out of the membrane. In a preferred embodiment, microfluidics devices having lipid-containing membranes within them are employed to measure lipid flux.

BRIEF DESCRIPTION OF DRAWINGS

FIGURE 1 illustrates one embodiment of a subject invention microfluidics cholesterol efflux measuring device.

FIGURE 2 illustrates a cross-section of the device of Figure 1 across 2-2.

FIGURES 3a and 3b illustrate additional embodiments of measurement protocol pathways which may be used with the subject invention microfluidics devices.

5 FIGURES 4a-4c illustrate additional embodiments of measurement protocol pathways which may be used with the subject invention microfluidics devices.

FIGURE 5 illustrates one embodiment of a subject invention microfluidics cholesterol efflux measuring device.

10 FIGURE 6 illustrates a cross-section of the device of Figure 5 across 6-6 also illustrating a pressure roller which is exterior to the device which can be used as an external stimulus to facilitate fluid movement within the device.

FIGURE 7 illustrates a cross-section of the device of Figure 5 across 7-7.

FIGURE 8 illustrates a segmented embodiment of the subject device.

15 **BEST MODE FOR CARRYING OUT THE INVENTION**

The present invention is directed to methods of measuring flux of cholesterol, lipids in general, and lipid-associated substances from and into fluids, particularly physiological fluids, and most preferably plasma. The method broadly involves contacting the fluid under investigation with a supported lipid bilayer
20 membrane, and measuring the change in the target substance(s) either directly or indirectly, *i.e.* by measuring the change in the amount or concentration of target substance(s) in the fluid after contact with the membrane, or measuring the change in target substance(s) on the membrane.

25 The method of the present invention is particularly well suited for measuring cholesterol and lipid efflux. Use of the inventive method with standard

isolation and measurement techniques allows the method to be used in macro or micro scale. Dedicated devices suitable for use in large hospitals and research institutions are possible, as well as smaller units more suitable for clinics and Doctor's offices. The technique is particularly well suited for use in microfluidics devices which may approximate the size of a credit card. This preferred mode of operation will be first described.

The preferred device and process may be simply described in relationship to the embodiments shown in Figures 1-2. In Figure 1, a cholesterol efflux measuring device is shown. The efflux measuring device of Figure 1 has five parallel efflux measuring pathways, each having an inlet, labeled 1-1d on Figure 1. This device has minimally two chambers, of a size such that the chambers can retain a targeted volume of blood plasma. The targeted volume may range from a fraction of a μl to a ml or more, but is preferably in the range of 1 to 500 μl , more preferably 10 μl to 100 μl in size.

Preferably, the device contains a "collection" chamber 13 which retains the blood-plasma deposited through inlets 1-1d. The device also contains a "membrane chamber" 7 which is connected to the collection chamber by a channel 15. The membrane chamber encloses a supported membrane containing cholesterol or other lipid or lipid-associated compound, the efflux of which is to be measured. A further "detection chamber" 9 is connected with the first chamber by a channel 11, connected with the membrane chamber by a further channel 5. Other chambers and channels may be present for specific purposes when desired, as later discussed. The second efflux measurement pathway contains analogous chambers and channels 7a, 9a, 11a, 13a, and 15a. Note that the chambers may have different spacings to accommodate increased pathway density, or to avoid interference when measuring efflux. One embodiment of a pathway is shown from the side in Figure 2. Note the membrane 10 within membrane chamber 7. Note that the chambers' "roofs" may be raised above the plane of the top of the device so that pressure may be applied to transfer fluid between chambers in this embodiment. In other embodiments, electrically stimulated piezoelectric or magnetoconstrictive pumps or other devices may be contained within the device itself.

In use, a blood plasma sample is introduced into the membrane chambers 7, 7a from inlet 1, 1d, etc., or, when used, from collection chamber 13 or 13a, where it is incubated, preferably under standard physiological conditions, for example 37 degrees C and standard pressure, for a designated period of time. It is during this period of membrane contact that cholesterol or other lipid of interest will flux into or out of the supported membrane. Following the membrane contact period, the sample is directed from the membrane chamber to the detection chamber. The resulting concentration of cholesterol or other lipid or lipid-associated substance is then measured. This change in concentration is preferably the difference between pre-test concentration in the plasma and the post-membrane contact concentration.

In an alternate mode, the collection chamber is a test tube containing the blood-plasma sample. A fluid moving system such as a pipette transfers the sample to a membrane chamber, which is a test tube containing the membrane support structure. Following the membrane incubation period, the sample is moved to a detection chamber by a fluid moving system where the resulting change in lipid concentration is measured.

Because cell culture is unnecessary, the method is both rapid and reproducible. Moreover, because of the small size of the device and its chambers, numerous parallel pathways may be positioned on the same device substrate as shown in Figure 1. These parallel pathways may utilize the same type of membrane and detection apparatus, allowing measurement of multiple different samples. Additionally, accuracy could be increased by measurement of the same sample in multiple channels. Multiple channels could also be used to measure different phenomenon, e.g. one set of channels and chambers measuring cholesterol efflux in one channel and influx in another. Other pathways may be membrane-free or may contain membranes having no cholesterol or other lipid or lipid-related substance whose concentration can change, thus serving as a control.

In the preferred device, collection, or "reservoir" chambers initially contain the blood plasma to be tested, either a single chamber associated with a single measurement protocol pathway; a single collection chamber associated with

multiple pathways is illustrated by Figure 3a; multiple arrays of single collection chambers and measurement protocol pathways as illustrated in Figure 1, or combinations of these such as illustrated by Figure 3b. Other combinations will be apparent to those skilled in the art.

5 The movement of blood plasma or other fluids (i.e., detection fluids) through the device can be accomplished by standard methods in this art. Such methods are by now well known to those skilled in microfluidics. Examples of the numerous techniques for fabricating devices, filters, valves, chambers, channels, etc., and methods for manipulation, transfer, and flow of fluids in such devices may
10 be found in numerous references, for example: B. He, et al., "Microfabricated Filters For Microfluidic Analytical Systems". *ANAL CHEM.* 1999 Apr 1; 71(7):1464-8. F.E. Reignier, et al. "Chromatography and Electrophoresis on Chips: Critical Elements of Future Integrated, Microfluidic Analytical Systems for Life Science". *TRENDS BIOTECHNOL.* 1999 Mar; 17(3):101-6. A. Folch, et al. "Molding of Deep Polydimethylsiloxane Microstructures for Microfluidics and Biological
15 Applications". *J BIOMECH ENG.* 1999 Feb; 121(1):28-34. A.M. Young, et al. "Contoured Elastic-Membrane Microvalves for Microfluidic Network Integration". *J BIOMECH ENG.* 1999 Feb; 121(1):2-6. S. Martinoia, et al. "A Simple Microfluidic System for Patterning Populations of Neurons on Silicon Micromachined Substrates".
20 *J NEUROSCI METHODS.* 1999 Feb 1; 87(1):35-44. N.H. Chiem et al. "Monoclonal Antibody Binding Affinity Determined by Microchip-Based Capillary Electrophoresis". PMID:9866711; UI:99083943. P. Schuck, et al. "Determination of Binding Constants by Equilibrium Titration with Circulating Sample in a Surface Plasmon Resonance Biosensor". *ANAL BIOCHEM.* 1998 Dec 1; 265(1):79-91. H.
25 Tan, et al. "Automation and Integration of Multiplexed On-Line Sample Preparation with Capillary Electrophoresis for High-Throughput DNA Sequencing". *ANAL CHEM.* 1998 Oct 1; 70(19):4044-53. D. Figeys, et al. "An Integrated Microfluidics-Tandem Mass Spectrometry System for Automated Protein Analysis". *ANAL CHEM.* 1998 Sep 15; 70(18):3728-34. L. Martynova, et al. "Fabrication of Plastic
30 Microfluid Channels by Imprinting Methods". *ANAL CHEM.* 1997 Dec 1; 69(23):4783-9. E. Delmarche, et al. "Patterned Delivery of Immunoglobulins to Surfaces Using Microfluidic Networks. *SCIENCE.* 1997 May 2; 276(5313):779-81.

N. Sutton, et al. "A Novel Instrument for Studying the Flow Behavior of Erythrocytes through Channels Simulating Human Blood Capillaries". MICROVASC RES. 1997 May; 53(3):272-81. P.C. Li, et al. "Transport, Manipulation, and Reaction of Biological Cells On-Chip Using Electrokinetic Effects. ANAL CHEM. 5 1997 Apr 15; 69(8):1564-8. W. Menz, et al. "Microstructure Technologies and Their Potential in Medical Applications". MINIM INVASIVE NEUROSURG. 1994 Sep; 37(1):21-7. P. Wilding, et al. "Manipulation and Flow of Biological Fluids in Straight Channels Micromachined in Silicon". CLIN CHEM. 1994 Jan; 40(1):43-7; and U.S. patent 5,842,787, "Microfluidic Systems Incorporating Varied Channel 10 Dimensions", which are herein incorporated by reference.

Thus, transport of blood plasma from one channel to another may be accomplished through application of pressure, electrical and/or magnetic fields, heat, ultrasonics, piezoelectric devices, pipetting devices, and other techniques. In general, transport which involves heating significantly in excess of 37 degrees C 15 should be avoided so that denaturation of functional moieties composing membranes, plasma, proteins, etc. will not occur.

Due to the small size of the various chambers and channels, the devices of the subject invention may be made quite small. For example, devices the size of a postage stamp or smaller are feasible, but it is contemplated that commercial 20 devices, largely for aid in handling, will be approximately the size of a credit card (ca. 6 cm by 9 cm) and perhaps several mm in thickness. The size is more limited by the necessity to introduce blood plasma into the device rather than other factors. Devices in which plasma is introduced by capillary action may be made thinner than other devices where injection or pipetting of plasma is envisioned. Large scale 25 "bench-top" devices may also be produced, although these are not preferred. Most preferably, the devices are "microfluidics" devices characterized by membrane chamber volumes of 100 μ L or less, preferably 10 μ L or less.

The material of the device must be biocompatible and protocol compatible. By "biocompatible" is meant that the device material must not cause 30 deactivation or denaturation of the blood plasma or its constituents in a manner which

would preclude valid test results. By "protocol compatible" is meant that the material in question must not disadvantageously interfere with the measurement of the desired test property. For example, in a test protocol where presence of a component in the measurement chamber will be assessed by fluorescence spectroscopy, use of a thermoplastic material which fluoresces under the same conditions so as to prevent measurement or destroy measurement accuracy would not be "protocol compatible".

Actual materials are well known, and include a variety of polymer substrates, e.g., polyurethanes, polyorganosiloxanes, polyolefins, and the like. Glass, quartz, monocrystalline and polycrystalline silicon are also suitable. Materials which are not suitable due to biocompatibility problems or protocol problems may be rendered suitable by surface treating, i.e., by siliconizing, hydrophobicizing, coating with biocompatible or protocol-compatible substances, etc. Hydrophilic or polar reactive surfaces may be rendered substantially inert by treatment with agents such as chlorotrimethylsilane, hexamethyldisilazane, and the like. It may be advisable to render channels designed for liquid transport not only compatible, but also hydrophobic, while leaving chambers compatible but hydrophilic. In this manner, plasma will tend to transfer readily from the microchannels to the chambers, leaving but little plasma in the former.

The membrane chamber will contain a biological, biosynthetic or biomimetic membrane which may be produced to contain or later treated to contain cholesterol, a lipid, or lipid-associated compound. By "biosynthetic" is meant that the membrane is grown by an in vitro cell culture technique which results in an appropriate membrane being formed. Such techniques are available from the prior art, but generally suffer from the disadvantage of being difficult to attach or mount in the chamber. Biological membranes are in vivo produced membranes which are isolated and mounted in the chamber. Biological membranes suffer from the disadvantages of being difficult to attach to the membrane chamber and by having variable composition.

Preferred membranes are biosynthetic membranes which are grown in situ in the chamber or component destined to become part of the chamber, and biomimetic membranes. Biomimetic membranes are membranes which approximate the behavior of true biological or biosynthetic membranes, but are produced by assembly of easily characterized and purified components without live cell growth.

For example, lipid bilayers have been proposed as suitable membrane mimics. Such layers are assembled in situ by providing an alkane thiol anchoring site followed by immersion in a solution containing lipid. Such techniques are described in more detail in Curtis W. Meuse, et al., "Hybrid Bilayer Membranes in Air and Water: Infrared Spectroscopy and Neutron Reflectivity Studies", *BIOPHYSICAL JOURNAL*, 74, March 1998, pp. 1388-1398, and Anne L. Plant, "Supported Hybrid Bilayer Membranes as Rugged Cell Membrane Mimics", National Institute of Standards and Technology, incorporated herein by reference. Such membranes have demonstrated membrane protein activity.

The use of phospholipid vesicles to spontaneously coat a covalently tethered hydrophobic layer on metal with a monolayer of solvent-free lipid has opened up a new era in biomimetic model membranes. Reference may be had to J. Spinke, J. Yang, H. Wolf, M. Liley, H. Ringsdorf and W. Knoll, *BIOPHYS. J.* 1992, 63, 1667-1671. H. Lang, C. Duschl, M. Gratzel, and H. Vogel, *THIN SOLID FILMS* 1992, 210/211, 818-821. A.L. Plant, *LANGMUIR* 1993, 9, 2764-2767. Alkanethiol/phospholipid bilayers may be referred as "hybrids" because they consist of both natural and synthetic components. The use of alkanethiols provides a distinct advantage over other planar model membranes. The alkanethiols can form a complete hydrophobic layer at metal surfaces as shown in R.G. Nuzzo and D.L. Allara, *AM. CHEM. SOC.* 1983, 4481-4483, and provide the driving force for the formation of a complete bilayer. The covalent association with the surface is insensitive to changes in buffer, pH, ionic strength, or lipid composition. Fabrication is easy since both the monolayer preparation, and the formation of the bilayer, are self-assembly processes. Hybrid bilayer membranes can be kept intact and studied for months; they are predicted to have significantly more mechanical stability than suspended bilayer membranes as disclosed by E.-L. Florin and H.E.

Gaub, *BIOPHYS. J.* 1993, 64, 375-383. Furthermore, because the tethered hybrid bilayer membrane is formed at a surface, many techniques that have not been generally applied to biological membranes are now accessible. The use of a metal support, such as gold, permits the application of electrochemical techniques for examining the insulating character of the lipid layers, and for assessing the activity of membrane protein pores lipase and redox enzymes, proton translocators, and ionophores. Also, the metal layer allows the use of surface plasmon resonance to examine the formation of these biomimetic membranes, and the association of solution-phase molecules to surface-membrane bound receptors. In these respects, please note J. Spinke, J. Yang, H. Wolf, M. Liley, H. Ringsdorf and W. Knoll, *op.cit.*, H. Lang, C. Duschl, M. Fratzel and H. Vogel, *op.cit.*; A.L. Plant, *op.cit.* M. Stelzle, G. Weissmuller and E. Sackmann, *J. PHYS.CHEM.* 1993, 97,2974-2981. A.L. Plant, M. Guegeuthkeri and W. Yap, *J. BIOPHYS* 1994, 67, 126-1133. C. Steinem, A. Janshoff, W.-P. Ulrich, M. Sieber, .-J. Galla, *BIOCHIM. BIOPHYS. ACTA* 1996, 1279, 169-180. S. Lingler, I. Rubinstein, W. Knoll and A. Offenhäusser, *LANGMUIR* 1997, 13, 7085-7091. K.T. Kinnear, H.G. Monbouquette, *LANGMUIR*, 1993, 9, 2255-2257. E. Torchut, C. Bourdillon and J. Laval, *BIOSENSORS & BIOELECTRONICS* 1994, 9, 719-723. J.D. Burgess, M.C. Rhoten and F.M. Hawkrige, *LANGMUIR* 1998, 14, 2467-2475. K. Seifert, K. Fendler and E. Bamberg, *J. BIOPHYS* 1993, 64 384-391. R. Nauman, A. Jonczyk, C. Hampel, H. Ringsdorf, W. Knoll, N. Bunjes and P. Gräber, *BIOCHEM. BIOENERG.* 1997, 42, 241-247. B.A. Cornell, V.L.B. Braach-Maksvytis, L.G. King, P.D.J. Osman, B. Raguse, L. Wiczorek and R.J. Pace, *NATURE* 1997, 387, 580-583. A.T.A. Jenkins, R.J. Bushby, N. Boden, S.D. Evans, P.F. Knowles, Q. Liu, R.E. Miles and S.D. Ogier, *LANGMUIR* 1998, 14, 4675-4678. B. Raguse, V. Graach-Maksvytis, B.A. Cornell, L.G. King, P.D.J. Osman, R.J. Pace and L. Wiczorek, *LANGMUIR* 1998, 14, 648-659. H. Lang, C. Duschl and H. Vogel, *LANGMUIR* 1994 10, 197-210. N. Bunjes, E.K. Schmidt, A. Jonczyk, F. Rippmann, D. Beyer, H. Ringsdorf, P. Gräber, W. Knoll and R. Naumann, *LANGMUIR* 1997, 13, 6188-6294. J.B. Hubbard, V. Silin and A.L. Plant, *BIOPHYS. CHEM.*, in press. L.M. Williams, S.D. Evans, T.M. Flynn, A. Marsh, P.F. Knowles, R.J. Bushby and N. Boden, *LANGMUIR* 1997, 13, 751-757. A.L. Plant, M. Brigham-Burke, E.C. Petralli and D. O'Shannessy, *ANAL. BIOCHEM.* 1995, 226, 342-348. S. Terrettaz, T. Stora, C.

Duschl and H. Vogel, *LANGMUIR* 1993, 9, 1361-1369. S. Heyse, O.P. Ernst, Z. Dienes, K.P. Hofmann and H. Vogel, *BIOCHEMISTRY* 1998, 37, 507-522. The planarity and stability of these bilayers also facilitate the use of atomic force microscopy, neutron reflectivity, ellipsometry, nonlinear optical spectroscopy, reflection-absorption infrared spectroscopy, and even vacuum techniques. The applicability of such a wide range of analytical techniques to biomimetic membranes opens up new avenues for studying the complex structure and function of biological membranes.

When phospholipid vesicles in aqueous media are exposed to the hydrophobic alkanethiol-coated surface, lipid molecules spontaneously assemble into a second layer over the alkanethiol monolayer. The process of addition of lipid to the monolayer can be followed by decreases in electrical capacitance with time. A.L. Plant, M. Brigham-Burke, E.C. Petralli and D. O'Shannessy, *ANAL. BIOCHEM.* 1995, 226, 342-348. The driving force for the self-assembly of phospholipids at an alkanethiol monolayer is presumably a hydrophobic effect, assuming that the result of addition of the phospholipid layer is the reduction of the free energy of the alkanethiol/water interface. Direct evidence for this was pursued by examining the effect of addition of a layer of phospholipid to the alkanethiol monolayer using surface enhanced Raman spectroscopy (SERS) and reflection-absorption infrared spectroscopy (RAIRS). See C.W. Meuse, G. Niaura, M.L. Lewis and A.L. Plant, *LANGMUIR*, 1998, 14, 1604. Both techniques indicated that changes in the alkanethiol monolayer are subtle. SERS was performed on monolayers in contact with water during bilayer formation. These measurements allowed assessment of the effect of the change in the microenvironment of the alkanethiols as water was replaced with the hydrophobic phospholipid layer. SERS indicated that the short chain alkanethiols, which are relatively disordered, are more affected by the addition of a layer of phospholipid than the longer chain thiols. Hexanethiol showed increases in the trans/gauche ratios of conformers of C-S, C-C, and terminal CH₃ groups, indicating an increase in intermolecular order. Changes in the C-H stretching region which indicate an increase in intermolecular order and are analogous to changes that accompany a decrease in temperature have also been observed. Longer chain alkanethiols showed little structural change due to the

addition of phospholipid. RAIRS measurements compare alkanethiol monolayers in air with alkanethiols as components of HBMs in air, so change in environment of the alkanethiol layer is expected to be less drastic than when the films are examined in water. Small changes in peak intensities are observed with RAIRS in the C-H stretching region. Increases in intensities of CH₂ peaks were more prominent as the alkanethiol chain length increased, while increases in the CH₃ peak intensities are not. These changes are also consistent with changes in alkanethiols induced by low temperatures. See R.G. Nuzzo, E.M. Korenic and L.H. Dubois, CHEM. PHYS. 1990, 93,767. These observations are consistent with producing biomimetic membranes by similar self assembly methods but employing surfaces hydrophobized by other methods, for example hydrophobization of hydroxyl group-bearing silica or polyvinyl alcohol substrates by reaction with long chain alkyl-substituted halosilanes.

Suitability of a particular membrane can be assessed by introducing cholesterol or other lipid into or onto the membrane, and contacting with blood plasma with or without a therapeutic agent such as lipid regulating compounds, including those presently marketed for their cholesterol and/or total lipid lowering ability. Following incubation at physiological temperatures, the plasma is assayed for lipid content relative to the original lipid content of the plasma. Known methods of lipid assay (e.g., for cholesterol, HDL, LDL, VLDL, etc.) may be used. It is most convenient to incorporate tritium labeled cholesterol or other lipid compound in the membrane and assess its transfer to plasma by measuring the radioactivity of the plasma when isolated from the membrane. These methods give the change in plasma membrane cholesterol/lipid content directly. Such membranes should be suitable for use in the membrane chambers herein. However, measurement of lipid efflux as previously described may also be correlated with lipid regulating activity in vivo, for example by methods disclosed in U.S. Patents 3,930,024; 4,711,896; 5,756,544; and Bisgaier et al. "A Novel Compound that Elevates High Density Lipoprotein and Activates the Peroxisome Proliferator Activated Receptor", J. LIPID RES., 39 (1998) pp. 17-30, all herein incorporated by reference.

The detection chamber must be capable of providing a response which can be related to the concentration or change in concentration of cholesterol, to lipid, or lipid associated compound. Measuring the radioactivity of plasma exposed to membranes incorporating radio-labeled, particularly tritium-labeled lipids, is preferred. However, other techniques such as Surface Plasmon Resonance, FT-IR, NMR, fluorescence spectroscopy, and the like may be used as well. Colorimetric or chemiluminescent determinations based on monoclonal antibody/chromogen techniques or reaction with a color-inducing reagent are also suitable.

The detection chamber may take the form of a narrow channel, provided that appropriate measurement sensitivity and freedom from background noise can be obtained to render measurements accurate and reproducible. For example, in U.S. patent 5,842,495, "Fourier Detection of Species Migrating in a Microchannel", devices are disclosed in which electrophoretically induced bands of target substances are measured by Fourier spectroscopy. Use of UV, IR, FTIR, and visible spectroscopy can be associated with measurement chambers having large volume or present as flow channels. Thus, the shape of the measurement chamber is not critical to the working of the invention.

In devices where radioactivity levels are measured, the device may have surfaces that contain, or are coated with, solid phase scintillant(s) that emit light upon exposure to radioactive decay particles such as beta particles. In this case the detection chambers would have surrounding ports or windows that are transparent to the light of wavelength specific to emitted light rays. In the case where electrical methods are used, electrodes may be embedded in the chamber, for example by incorporation of foils embedded in a laminate (for capacitive measurement) or plated electrodes (for capacitive methods or electrochemical methods). However, when spectrophotometric means are used, whether in the IR, UV, or visible portions of the spectrum, a portion of the device must be at least partially transparent to the portion of the spectrum used for measurement. Transparency to UV and visible light is easily accomplished by use of fused silica, quartz, or sapphire substrates or windows. Glass may be used where only visible light transparency is required. Plastic windows of polyacrylate, polycarbonate, optically clear polyethylene, polypropylene,

etc., may be used. For infrared transparency, inorganic salt and other compounds, e.g., bismuth sulfide, and the like are available. However, their use is somewhat limited due to expense, fragility, and chemical and biochemical activity. Traditional IR materials such as NaCl are generally out of the question unless the surfaces are suitably passivated. Certain polymers may be used if the adsorbance of interest does not correspond to the major adsorption bonds of these polymers. Neither the materials nor the methods of measurement should be viewed as limiting the scope of the invention.

Figure 4a illustrates a further embodiment of the present invention where a second membrane chamber 42 is located beyond the first membrane chamber 41. If the first membrane chamber contains a membrane doped with cholesterol, the second chamber membrane may contain no cholesterol. Following incubation of plasma in the first membrane chamber to remove cholesterol, the plasma is introduced into the second chamber and incubated. Measurement of cholesterol in the second chamber will determine the degree of redeposition of cholesterol (or other lipid) from plasma, while the measurement of cholesterol in the measurement chamber will give net cholesterol removal. The collection chamber in Figure 4a is 40, while the measurement chamber is 43.

In Figure 4b, a device which achieves a similar result by a different mechanism is provided. In this device, following incubation in the membrane chamber 41, the effluent is split, one sample portion passing directly to a measurement chamber 43, the second sample portion directed to a second membrane chamber 42 and from thence to a second measurement chamber 43a. In Figure 4c, the same measurement chamber 43 is used for both samples. The cholesterol of the first sample is measured and the sample pumped to the "waste" chamber 44. The second sample is then pumped from the membrane chamber 41 into the measurement chamber. In Figure 4c, chamber 45 contains a wash liquid which may optionally be used to wash any interfering plasma from the measurement chamber 43 into the waste chamber 44 prior to introduction of the second plasma sample to be measured.

A hypothetical device is shown in Figures 5-7. In Figure 5, a device with three "parallel" pathways and a single collection chamber 51 is shown. The collection chamber 51 and three membrane chambers 53, 55 and 57 are noticeable from the exterior of the device in this embodiment, as slight bulges. The inlet is 50. 5 The inlet is connected to the collection chamber through channel 52, and from the collection chamber to the membrane to the membrane chambers by channels 54, 56, and 58. The respective membrane chambers are connected to measurement chambers 59, 61, and 63 by channels 60, 62, and 64. In Figure 6, the device, which may measure 6x9 cm, is shown sectioned in a plane parallel to the device surface across 10 6-6 of Figure 5. The blood plasma reservoir, into which plasma is introduced, communicates with inlet 50 which may be configured with a soft compliant material 65 around the port periphery to act as a seal as plasma is introduced from microsyringe or micropipette. A portion of the membrane chambers may be inert, i.e., devoid of membrane. For example, chamber 53 may be an inert, membrane-free channel, while chamber 55 and 57 may contain a bilayer lipid membrane doped 15 with tritium labeled cholesterol. Because the level of tritium is very low and the beta particle emitted by tritium radioactive decay is of such low energy, such devices are safe to handle and to transport.

A side, cross-section of the device through the reservoir and one set 20 of channels (across 6-6) and chambers is illustrated in Figure 6. It can be seen that the body of the device is made of injection molded or micromachined plastic, the membrane chamber having a gold coating 68 and overlying bilayer lipid membrane 69. This coating and membrane might also be applied to the roof of the membrane chamber, but for ease of manufacture is limited to one side only. At 66 is a polymer, 25 foil, or composite cover which is adhesively bonded, fused, or prepared by solvent casting or evaporative techniques, etc., which contains protuberances above the reservoir and membrane chambers. Positioned above and partially compressing the reservoir 51 is exterior pressure roller 70 which has already forced some of the reservoir plasma 71 into channel 56 toward membrane chamber 55. The roller can 30 be advanced across the device to successively transfer fluid to successive chambers. More than one roller moving in varied directions may be used. Magnetorestrictive, piezoelectric, or other pumping methods may be used. All microfluidics transfer

or pumping methods now known or which may be hereafter developed are suitable for use herewith, including various valves, one way flow devices, etc. In Figure 7 is shown the device across 7-7 of Figure 5. In Figure 7, the channels 60 and 64 may be seen, as well as measurement chamber 61. Note that since no fluid will be transferred from the measurement chamber in this device, the chamber is recessed rather than elevated. Note that the device need not be configured to permanently contain the plasma. However, by doing so, the devices may be discarded without significant biohazard risk.

In addition to the microfluidics devices heretofore described, the present invention is also useful for analytical techniques which are more traditional in character. For example, much larger scale supported membranes may be prepared, contacted with fluid whose lipid flux is to be ascertained, and the change in amount and/or concentration of the target substance(s) measured on the fluid, the membrane, or both, by standard macro (or micro) scale techniques similar to the analytical techniques described previously herein.

In a preferred method, the bilayer lipid membranes are prepared on the surface of small beads or particles, contacted with the fluid under investigation, and separated from the fluid for measurement of amount and/or concentration of target substances associated with the bead-supported membrane and/or contained in the fluid. Separation of the beads from the fluid allows for accurate and reproducible measurement.

As a non-limiting example, glass, metal, or polymer beads may be gold plated by standard techniques, reacted with alkane thiol or other hydrophobicizing substance, and contacted with phospholipid, all as previously described, to form bilayer membranes supported on the beads. Columns containing these beads may then be prepared. Both large columns resembling chromatographic or ion-exchange columns may be made, or much smaller columns such as columns within glass capillary tubes, pipets, micropipets, syringes, etc. When advisable, the columns may be temporarily sealed with sealing devices such as stoppers, caps,

valves, etc., and may be optionally filled with a non-interfering fluid such as a plasma substitute, physiological saline, sterile water, or the like.

In use, the columns, syringes, etc., containing the bead-supported membranes are contacted with the fluid whose lipid flux is to be measured, either statically (*i.e.*, by drawing the fluid into the syringe) or dynamically, *i.e.*, by passing
5 a (preferably) known volume of fluid through a column containing the beads. The beads and fluid are then separated by physical methods or by washing, etc., and the necessary concentrations measured.

Rather than enclose the beads in a column, syringe, or other device,
10 a supply of beads, either in the form of a larger quantity which is weighed out or otherwise dispensed appropriately, or supplied in the form of vials, ampules, etc., already containing a fixed quantity of beads, is contacted with the fluid of interest for a given period of time, the beads separated, and the necessary measurements made. The beads may, for example, be separated by simple filtration, centrifugation, or
15 similar techniques, or if rendered magnetic or otherwise subject to magnetic separation, may be separated by such techniques. See, *e.g.*, U.S. patent 3,970,518, "Magnetic Separation of Biological Particles"; U.S. patent 4,777,145, "Immunological Assay Method Using Magnetic Particles"; U.S. patent 4,935,147, "Particle Separation Method"; U.S. patent 4,115,534, "In Vitro Diagnostic Test";
20 and the references cited therein, all incorporated herein by reference.

While the separation techniques discussed immediately above have been contemplated for use with beads or particles supplied as such, these techniques are also suitable for use with beads supplied in chromatographic columns, pipettes, syringes, etc., by removing the beads and appropriately separating them from any
25 remaining fluid by one of the above techniques.

Example 1

A device is constructed from a plate of quartz measuring 2 cm x 9 cm x 3 mm. At a narrow end face of the device (2 cm x 3 mm) is machined a round hole and channel which proceeds from the hole at an angle, exiting on one surface to produce an "exit hole" about 1 cm from the hole end. The hole, its channel, and subsequent channels and chambers are produced by solution micromachining. From this exit position, a microchamber is etched, having a diameter of 10 mm and a depth of 1 mm (creating a chamber volume of 25 microliters). A channel is etched from this microchamber to a second microchamber having a diameter of 0 mm and a depth of 1 mm, and from this "membrane" chamber, a microchannel is etched to a measurement chamber of the same size. The width and depth of the microchannels are the same at approximately 0.01 mm. The entire device is treated with dilute alkali to produce a hydrophilic surface. The hydrophilic surfaces of the microchannels and the membrane chamber are treated with chlorodimethyloctadecylsilane to render them very hydrophobic. A lipid bilayer is then formed on the hydrophobic surface of the membrane chamber by the method of Meuse et al. but without the gold layer, the long chain alkyl-derivatized hydrophobic layer substituting for the alkanethiol-treated gold coating.

Two covers are utilized. In a first device, a plastic cover of high density polyethylene having slight bulges thermoformed into the cover at positions corresponding to the plasma reservoir and membrane chamber is bonded to the quartz support by means of an organopolysiloxane adhesive. The adhesive is mask-sprayed onto the quartz and the cover pressed on.

In a second device, the plastic cover used in the first device is reflectively metallized in the area which will cover the measurement chamber, and the coating rendered inert by a curable silicone coating.

The first device is suitable for radioactivity assay measurement of the lipid content in the measurement chamber if, for example, the plastic cover is synthesized or coated with solid phase scintillants responsive to low energy

radioactive decay particles. The second device is suitable for spectrophotometric determination in the UV, visible, and near IR portions of the spectrum. The reflective coating covering the measurement chamber doubles the path length of the chamber. A transparent cover could also be used for transmitted light detection methods.

Example 2

A substrate is produced by machining polyethylene to the same pattern as that of Example 1. However, the membrane cavity is electroless gold plated to a thickness of about 50 Å and a bilipid biomimetic membrane prepared as taught by Meuse by hydrophobicizing with octadecanethiol followed by phospholipid treatment solution. The non-functioning surface areas of the substrate are plasma etched to increase susceptibility to adhesion, and a cover as in the first device of Example 2 is attached employing an organopolysiloxane adhesive. The lipid bilayer is doped with tritium labeled cholesterol by incubating the layer with a solution containing the tritiated cholesterol for a brief period of time.

Example 3

The reservoir of the device of Example 2 is filled with human whole blood plasma containing the equivalent of 100 mg/μL of a lipid efflux increasing substance such as plasma high density lipoprotein. A pressure roller is rolled over the top of the device over the reservoir chamber, transferring blood plasma into the membrane chamber. The device is incubated at 37 degrees C for 1 hour, following which the pressure roller is rolled across the top of the device over the membrane chamber, forcing blood plasma into the measurement chamber. Scintillation based counting over the measurement chamber indicates that a level of radiation consistent with the presence of tritium labeled cholesterol. A similar process but employing no high density lipoprotein results in a measurable decrease in the level of radioactivity detected in the measurement chamber.

The chambers in the claimed devices and claimed processes are labeled as to their function. A “reservoir chamber” is a collection chamber devoid of membrane, or having a membrane which does not defeat the ability of the device to measurably distinguish between an experimental protocol and a control. The
5 reservoir chamber is preferably a chamber adjacent the inlet and is preferably separated from the inlet by a one-way valve or other device which prevents egress of plasma out the inlet. The inlet may be simply plugged when the reservoir is adequately filled. Valves or one way flow devices are preferredly used in all pathways.

10 The “membrane chamber” is a chamber containing a bilayer lipid membrane or other membrane which acts biologically or as a biomimic to interact with one or more cholesterol, lipid, or lipid-associated compounds and exert a measurable influence on at least one concentration thereof when in the presence of an agent contained in the plasma which mediates (changes) lipid content or
15 distribution, or in the presence of plasma not containing such an agent but desirous of itself being tested for lipid mediating activity. An agent or plasma sample mediates lipid content when one or more of cholesterol, lipid, or lipid-associated compounds' concentration changes in the presence of the agent or plasma sample, and changes to a different degree when not in the presence of the agent.

20 By “lipid” and “lipid-associated” are meant any of various substances that are soluble in nonpolar organic solvents or are associated with said substances.

By “non-contacting measurement chamber” is meant a chamber adapted to measurement of the concentration of at least one of cholesterol, lipid, or lipid-associated compound without actual physical contact of the measurement means
25 with the plasma. A “contacting measurement chamber” is a measurement chamber adapted to make such a measurement with contact of the blood plasma with a portion of the measuring instrument. In such cases, the subject device integrity will be compromised and the measuring instrument will require cleaning or a replaceable covering. “Measuring chamber” is inclusive of both a contacting measuring
30 chamber and a non-contacting measuring chamber.

By the term "waste chamber" is meant a chamber within a device adapted to receive fluid such that another chamber may be emptied and refilled. By the term "flushing chamber" is meant a chamber containing plasma from the reservoir which does not pass through the plasma-altering membrane chamber, or an inert fluid which is used to "flush" or "rinse" prior fluid from a chamber,
5 particularly a measurement chamber.

By the term "external stimulus" is meant the application of pressure, vibrational energy, magnetic field, electrical field, electrical potential, centrifugal force, etc., by an apparatus which is not part of the microfluidics device itself. An
10 external stimulus such as a pressure roller, gas pressure, vacuum, etc., may be used to move fluid without any active structure in the measuring device. Alternatively, the external stimulus may cause an internal transfer device such as a piezoelectric or magnetic device to transfer fluid.

By the term "non-invasive measuring method" is meant an electrical, magnetic, electromagnetic, radiation-sensitive, spectrophotometric or like measuring
15 method wherein no portion of the measuring instrument directly contacts the plasma sample. By "invasive measuring method" is meant a method where there is direct contact between the plasma and a portion of the measuring instrument. By "measuring method" and "measuring" is meant the process of measuring a physical
20 quantity associated with an amount or concentration or change in amount or concentration of cholesterol, lipid, or lipid-associated compound, whether invasive or non-invasive.

By the term "chamber" is meant a chamber for holding fluid in the subject devices. The term "microchamber" may be used for devices where the fluid
25 volume in a chamber will be less than 100 μL .

By the term "bioactive" with respect to the membrane is meant a membrane which will mimic a biological system under physiological conditions such that measurement of lipid efflux will be a meaningful measurement.

By "integrated device" is meant a complete device which contains all of at least a membrane chamber and a measurement chamber, and optionally one or more reservoir chambers, flush chambers, and/or waste chamber(s). By "partially integrated segment" is meant a plurality of segments adapted to mate with each other
5 in such a fashion so as to provide, in combination, the necessary chambers described above, and optionally the optional chambers. A complete, segmented device comprised of a plurality of partially integrated segments is illustrated in Figure 8. This device comprises a reservoir section 81, a membrane chamber segment 83, and measurement segment 85. Partially integrated segment use is not preferred.

10 By the terms "column" and "hollow tube" and similar terms is meant a device which is similar in function, and generally also similar in shape to known columns and hollow tubular structures used in analysis, *i.e.*, chromatographic columns and tubes, pipettes (both macro and micro scale), burettes, glass tubes, glass tubes containing filter frits, syringes, etc. These devices may also be associated with
15 filters, valves, caps, etc.

By the term "change in concentration", "change in mass", and like terms is meant the difference between the initial mass or concentration and a second mass or concentration. Where the initial mass or concentration of a measured substance is zero, the absolute measurement of the second and preferably final
20 concentration will be the difference. In most cases, the terms "concentration" and "mass" are interchangeable, as both are measurements of the "amount" or "relative amounts" of lipid or lipid-associated substance.

While embodiments of the invention have been illustrated and described, it is not intended that these embodiments illustrate and describe all
25 possible forms of the invention. Rather, the words used in the specification are words of description rather than limitation, and it is understood that various changes may be made without departing from the spirit and scope of the invention.

WHAT IS CLAIMED IS:

1. A method for measuring changes in mass of one or more lipids or lipid-associated compounds in a membrane by contact with blood plasma with or without one or more lipid mediating agents, said method comprising:
 - 5 contacting said blood plasma with said membrane under physiological conditions in a chamber of a lipid efflux measuring device for a time period sufficient to bring about said change in lipid or lipid-associated compound;
transferring said blood plasma through a channel into a measurement chamber; and
 - 10 measuring an amount, concentration, mass or change in amount or concentration or mass of lipid or lipid-associated compound in said measurement chamber which is related to the amount of lipid or lipid-associated compound removed from said membrane.

2. The method of claim 1, further comprising:
 - 15 prior to contacting said blood plasma with said membrane in said membrane chamber, introducing said blood plasma into a reservoir chamber and transferring said blood plasma from said reservoir chamber through a microchannel into said measurement chamber.

3. The method of claim 1, wherein said device is a microfluidics
20 device.

4. A method for measuring changes in mass and/or concentration of one or more lipids or lipid-associated compounds contained in a fluid in contact with a supported bilayer lipid membrane, said method comprising:
 - 25 contacting said fluid with a supported bilayer lipid membrane for a period of time sufficient to accommodate a change in lipid or lipid-associated compound mass or concentration in said fluid;
separating said fluid from said supported bilayer lipid membrane; and
measuring the change in lipid and/or lipid-associated compound mass and/or concentration in said supported bilayer lipid membrane and/or in said fluid.

5. The method of claim 4, wherein said supported lipid bilayer membrane is supported on beads or particles.

6. The method of claim 5, wherein said beads or particles are contained within a container adapted to receive said fluid.

5 7. The method of claim 5, wherein said beads or particles are capable of magnetic separation from said fluid.

8. The method of claim 4, wherein said membrane is supported on the interior wall of a hollow tube.

9. The method of claim 6, wherein said container is selected from
10 the group consisting of a column, a pipette, and a syringe.

10. A microfluidics device suitable for the testing of lipid-mediating agents contained in blood plasma, or the lipid mediating propensity of a blood plasma sample not containing an added lipid-mediating agent, said device comprising:

15 a substrate of a biochemical and protocol compatible material or a material which has been rendered biocompatible and protocol compatible on its plasma-contacting surfaces by surface treatment thereof;

said substrate having an inlet for blood plasma;

20 said substrate containing at least one membrane reservoir containing a bioactive membrane containing one or more lipids whose efflux from said membrane is desired to be measured, said membrane chamber in direct or indirect communication with said inlet;

25 said substrate containing at least one measurement chamber adapted to enable measurement of said one or more lipids whose efflux is desired to be measured;

said membrane chamber and said measurement chamber connected by a channel;

a transfer device internal to said microfluidics device but activated by an external stimulus so as to transfer said plasma from one chamber to another chamber, or said device configured to transfer fluid from one chamber to another chamber without use of an internal transfer device.

5 11. The microfluidics device of claim 10 wherein said device further comprises:

 a reservoir chamber, said reservoir chamber in communication with said membrane chamber by means of a further microchannel, and in communication with said inlet.

10 12. The microfluidics device of claim 10, wherein said membrane is a bilayer lipid membrane produced by laying down a bilayer of phospholipid onto a hydrophobicized support.

 13. A method of measuring the change in lipid or lipid-associated compound contained in a physiological fluid, comprising:

15 supplying beads coated with a bilayer lipid membrane, said beads amenable to separation from the fluid by magnetic means;

 contacting said beads with said fluid for a time sufficient to effect a change in lipid concentration in said fluid by contact with said bilayer lipid membrane;

20 magnetically separating said beads from said fluid; and

 measuring the amount of lipid or lipid-associated compound in at least one of said beads or said fluid separated from said beads.

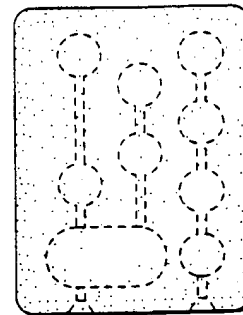
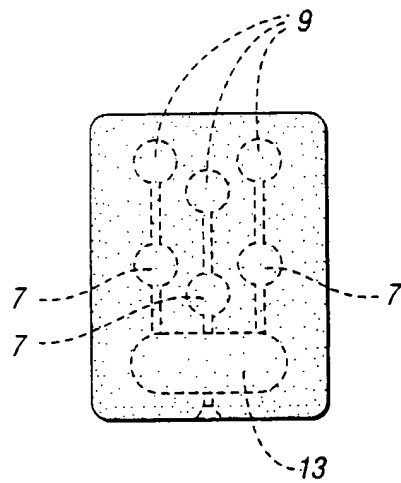
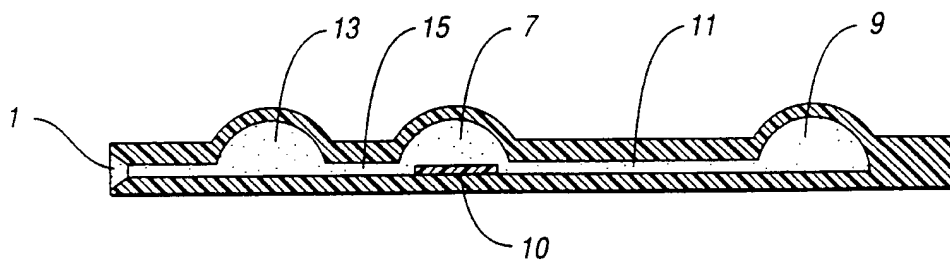
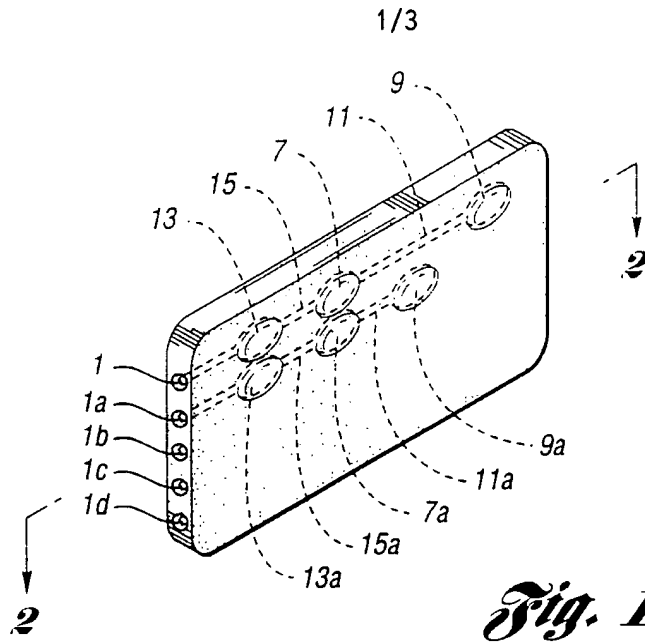

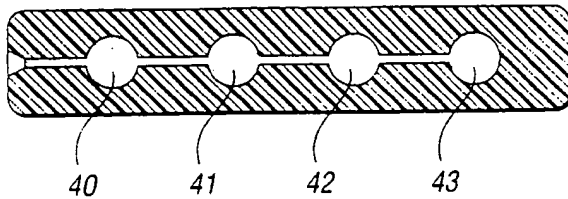

Fig. 4a

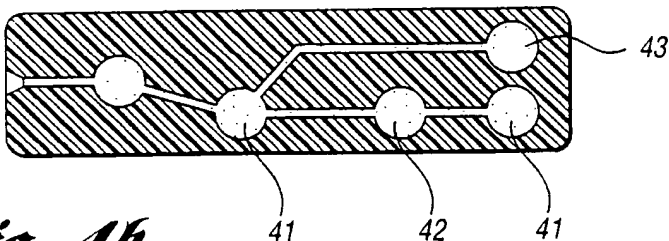

Fig. 4b

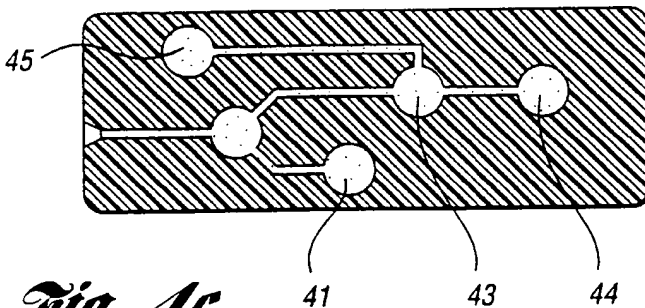

Fig. 4c

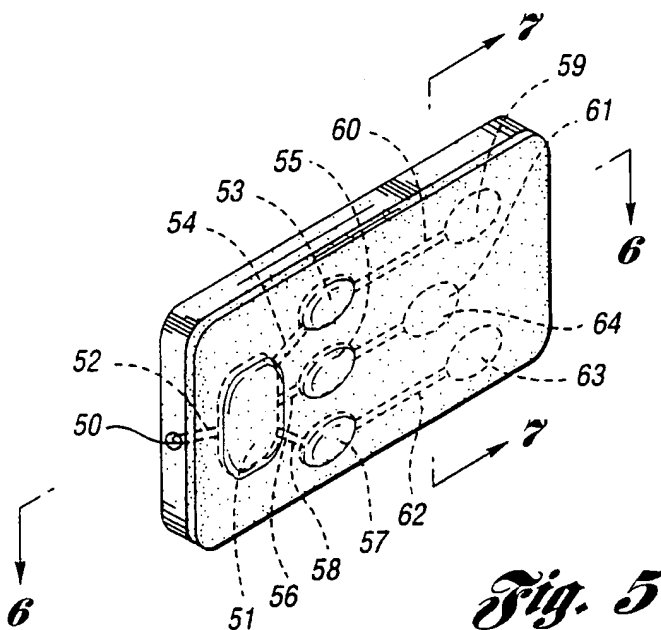

Fig. 5

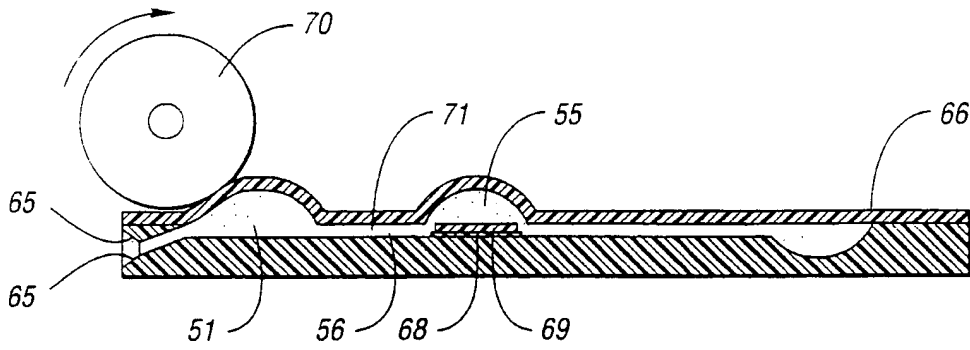

Fig. 6

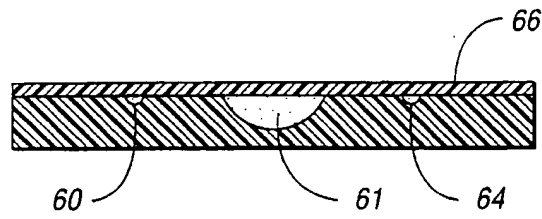

Fig. 7

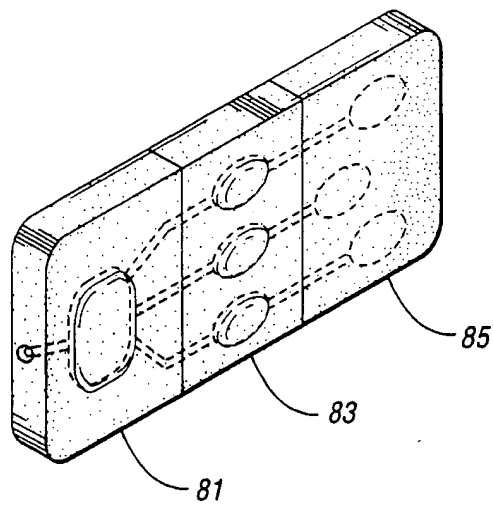

Fig. 8

INTERNATIONAL SEARCH REPORT

International application No.
PCT/US00/20310

A. CLASSIFICATION OF SUBJECT MATTER IPC(7) : G01N 15/06, 31/00, 33/48, 33/92 US CL : 436/13, 71, 139; 422/68.1 According to International Patent Classification (IPC) or to both national classification and IPC		
B. FIELDS SEARCHED Minimum documentation searched (classification system followed by classification symbols) U.S. : 436/13, 71, 139; 422/68.1 Documentation searched other than minimum documentation to the extent that such documents are included in the fields searched Electronic data base consulted during the international search (name of data base and, where practicable, search terms used) WEST 2.0		
C. DOCUMENTS CONSIDERED TO BE RELEVANT		
Category*	Citation of document, with indication, where appropriate, of the relevant passages	Relevant to claim No.
Y	US 5,922,554 A (FIELDING et al) 13 July 1999, col. 2, line 23- col. 3, line 47.	1, 4, 10, 12
Y,P	US 6,066,448 A (WOHLSTADTER et al) 23 May 2000, col. 3, line 40 - col. 4, line 18.	1
A	US 5,770,355 A (BROCIA) 23 June 1998, see entire document.	
<input type="checkbox"/> Further documents are listed in the continuation of Box C. <input type="checkbox"/> See patent family annex.		
* Special categories of cited documents: "A" document defining the general state of the art which is not considered to be of particular relevance "E" earlier document published on or after the international filing date "L" document which may throw doubts on priority claim(s) or which is cited to establish the publication date of another citation or other special reason (as specified) "O" document referring to an oral disclosure, use, exhibition or other means "P" document published prior to the international filing date but later than the priority date claimed	"F" later document published after the international filing date or priority date and not in conflict with the application but cited to understand the principle or theory underlying the invention "X" document of particular relevance; the claimed invention cannot be considered novel or cannot be considered to involve an inventive step when the document is taken alone "Y" document of particular relevance; the claimed invention cannot be considered to involve an inventive step when the document is combined with one or more other such documents, such combination being obvious to a person skilled in the art "&" document member of the same patent family	
Date of the actual completion of the international search 01 OCTOBER 2000	Date of mailing of the international search report <div style="text-align: center; font-size: 1.2em; font-weight: bold;">18 OCT 2000</div>	
Name and mailing address of the ISA/US Commissioner of Patents and Trademarks Box PCT Washington, D.C. 20231 Facsimile No. (703) 305-3230	Authorized officer <div style="display: flex; justify-content: space-between;"> <div style="text-align: center;"> LATOYA CROSS Telephone No. (703) 308-0661 </div> <div style="text-align: center;"> DEBORAH THOMAS <i>DTA</i> PARALEGAL SPECIALIST </div> </div>	